

Miller Du-Op™

Issued February 2003 • Index No. ED/10.9

Engine-Driven
Welder/Generator 

Quick Specs



Heavy Industrial Applications

Pipe Welding
Structural

Processes

Stick (SMAW)
MIG (GMAW)
Flux Cored (FCAW)
DC TIG (GTAW)
Air Carbon Arc (CAC-A)
Single Weld Mode:
3/8 in (9.5 mm) Carbons
Dual Weld Mode:
1/4 in (6.4 mm) Carbons

Output Range

Single Weld Mode: (Right side) CC/DC 30–600 A
Dual Weld Mode: (Both sides) CC/DC 15–300 A
CV/DC 10–32 A

Weld Output Rated at 104°F (40°C)

Single Weld Mode: 550 A at 30 VDC, 40% Duty Cycle
Dual Weld Mode: 275 A at 31 VDC, 40% Duty Cycle

Generator Output Rated at 104°F (40°C)

5,500 Watts Peak — 4,000 Watts Continuous

Weight Net: 2005 lb (909 kg) Ship: 2032 lb (922 kg)

The Power of Blue.®

Multi-arc welding is here! One dependable engine and two high-performance arcs allow operators to work independent of each other. It's a one-of-a-kind, go-anywhere engine drive.

Increase profits with this multi-arc machine by completing even your most demanding jobs in half the time compared to conventional engine-driven welders. With two arcs in one engine drive, fewer machines are required for a job.

Double the amperage output with a switch that parallels both outputs to a single side. This provides a safe and easy way to run large electrodes, stud weld, or carbon-arc gouge.

5,500 watts of AC generator power independent of welding output. Two 120 V, 20 A GFCI duplex receptacles. Two 230 V, 20 A duplex receptacles.



Two 14-pin remote controls can be used for precise adjustment of amperage or voltage along with contactor.

Hot Start™ provides positive stick electrode starts to make it easy to start all types of electrodes.

Weld meters — digital ammeter and presettable voltmeter allow monitoring of welding output for each welder.

Arc control (DIG) allows the arc characteristics to be changed for specific applications and electrodes. Smooth running 7018 or stiffer, more penetrating 6010 electrodes.

Thermal overload protection prevents machine damage if the duty cycle is exceeded or airflow is blocked.

TRUE BLUE®
3YR. WARRANTY

Welder/generator is warranted by Miller for 3 years, parts and labor.
Engine is warranted by Deutz for 2 years.

MADE IN **USA**
APPLETON, WI



Miller Electric Mfg. Co.
An Illinois Tool Works Company
1635 West Spencer Street
Appleton, WI 54914 USA

International Headquarters
Phone: 920-735-4505
USA FAX: 920-735-4134
Canadian FAX: 920-735-4169
International FAX: 920-735-4125

Web Site
www.MillerWelds.com



Specifications (Subject to change without notice.)



Welding Mode	Weld Stations Available	Weld Output	Weld Output Range	Weld Output Rated at 104° F (40° C)	Max. Open-Circuit Voltage	Generator Output Rated at 104° F (40° C)	Dimensions	Weight Without Fuel*
Single	1 (Right side)	CC/DC	30–600 A	550 A at 30 VDC, 40% Duty Cycle	85	Peak: 5500 watts Continuous: 4000 watts, 34/17 A, 120/240 VAC, while welding	H: 47-5/8 in (1210 mm) W: 31-1/4 in (794 mm) D: 60-1/2 in (1537 mm)	Net: 2005 lb (909 kg) Ship: 2032 lb (922 kg)
Dual	1 or 2 (Both sides)	CC/DC CV/DC	15–300 A 10–32 V	275 A at 31 VDC, 40% Duty Cycle	85 49			

*Additional 176 lb (80 kg) when fuel tank is full.

Engine (Subject to change without notice.)

Engine Brand	Features	HP	Type	Weld Speed	Fuel Capacity	Oil Capacity	Coolant Capacity	Automatic Engine Shutdown
Deutz, F3L-912	The legendary EPA-certified, direct-injected, air-cooled engine with full-load sound levels of 83 dB @ 7 m (108 Lwa) . Right-side service access with service intervals of 500 hours for oil and filters .	42	Three-cylinder, industrial, air-cooled, diesel	1800 RPM Idle: N/A	25 gal (95 L)	9 qt (8.5 L)	Air	Broken cooling blower belt

Control Panel

Front Panel

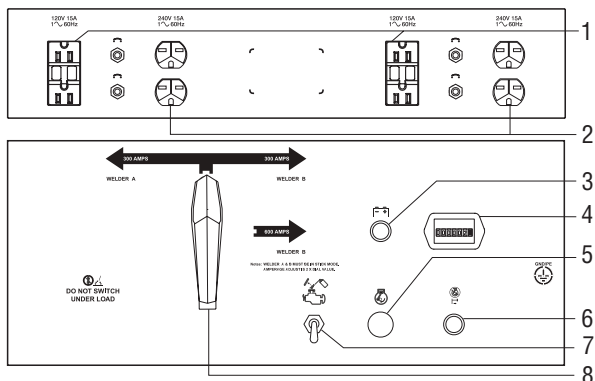

- 120 VAC, 20 A GFCI Duplex Receptacle and Circuit Breakers
- 240 VAC, 20 A Duplex Receptacle and Circuit Breakers
- Battery Charging Warning Light
- Engine Hour Meter
- Engine Start Button
- Manual Stop Control
- Ether Starting Aid Switch (Optional)
- Separate/Parallel Switch

Side Panels

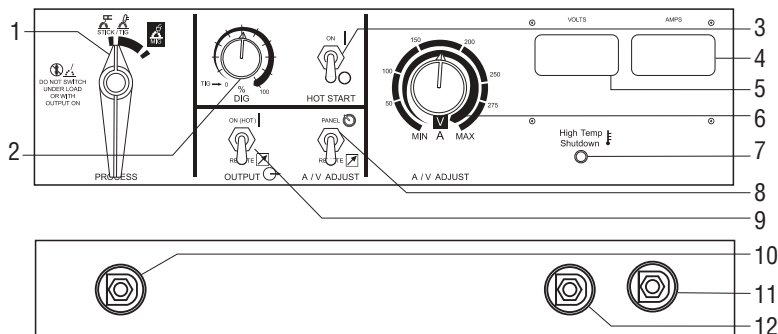

- Process Selector Switch
- Arc Force (DIG) Control
- Hot Start Switch
- Ammeter
- Voltmeter
- Amperage/Voltage Control
- High Temperature Shutdown Light
- Remote Amperage/Voltage Control Switch
- Output (Contactor) Switch
- Negative Weld Output Terminal
- CC Weld Output Terminal
- CV Weld Output Terminal

Performance Data

DUTY CYCLE

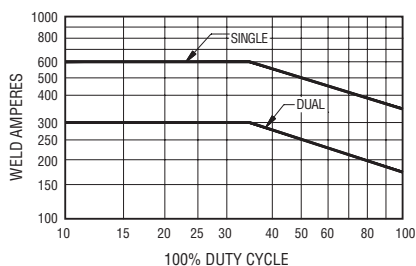

AUXILIARY POWER

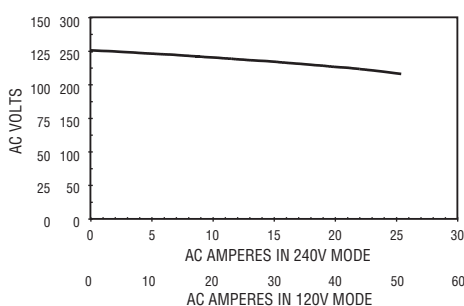

FUEL CONSUMPTION

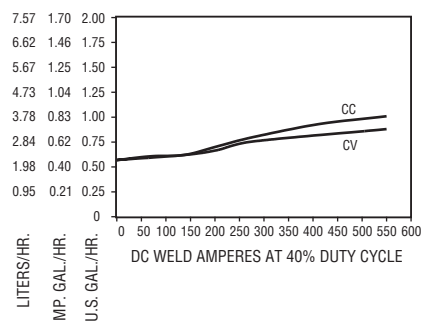

Genuine Miller Options and Accessories

Options

Ether Starting Aid Kit #041 481 Field Ether system recommended for frequent starting below 10° F (-12° C). Ether tank is not provided with kit.

FA-1D Lockable Flame Arrestor Fuel Cap #042 726 Field

Fuel cap can be padlocked to prevent vandalism. A built in flame arrestor prevents flames or sparks from entering the fuel tank.

Spark Arrestor (Muffler) Kit #041 928 Field

Prevents particles from leaving the muffler that could potentially start a fire. Mandatory when operating on California grasslands, brush, or forest-covered land, and all National Forests. For other areas, check your state and local laws.

Wire Feeders



SuitCase 8VS™ Wire Feeder #194 890

SuitCase™ 12VS Wire Feeder #194 941

Lightweight, portable, voltage-sensing wire feeder for .045/.052 flux core and .035/.045 hard wire. Includes secondary contactor and gas valve. Requires gun and drive roll kit. See Lit. Index No. M/6.4.

MIG (GMAW) Guns

Miller produces a complete line of dependable MIG guns. Check literature for complete details. See Lit. Index Nos. M/10.0 and M/13.4.

Stick (SMAW) Welding

No. 2 Stick Welding Accessory Kit, 15 ft #173 851

50 ft (15 m) No. 2/0 electrode cable with electrode holder and 50 ft (15 m) No. 2/0 work cable with work clamp.

2/0 Stick Cable Set, 100/50 ft #043 952

Consists of 100 ft 2/0 electrode cable and holder, and 50 ft work cable and clamp. 300 A, 100% duty cycle.

Remote Controls and Switches

RHC-14 Hand Control #129 340

Miniature hand control for remote current and contactor control. Dimensions: 4 x 4 x 3-1/4 in (102 x 102 x 82 mm). Includes 20 ft (6 m) cord and 14-pin plug.

Extension Cords for 14-Pin Remote Controls

#122 973 25 ft (7.6 m)

#122 974 50 ft (15.2 m)

#122 975 75 ft (22.9 m)

Trailers and Hitches



HWY-224 Trailer #043 805

A 2650 lb (1202 kg) capacity highway trailer. Welded steel tubing frame, heavy-duty axle with roller bearing hubs and leaf-spring suspension. The HWY-224 comes with jack stand, 2 in (50 mm) ball hitch, fenders and lights.

OFR-224 Trailer #043 802

A 2650 lb (1202 kg) capacity off road trailer. Welded steel tubing frame, heavy-duty axle with roller bearing hubs and leaf spring suspension. The OFR-224 comes with jack stand and 2 in (50 mm) ball hitch.

Lunette Eye 2-1/2 in (64 mm) #043 824

For use with both 224 trailers.

Cable Tree #043 826

Provides an area to conveniently wrap weld cables and extension cords. Works on all 224 and 430 trailers.



HWY-430 Tandem Axle Trailer #043 806

Smooth riding with 3750 lb (1701 kg) capacity. Includes: adjustable hitch for level operation, a hand operated parking brake, a self-actuating hydraulic brake system and a break-away device to lock brakes if the trailer comes loose. It also includes jack stand, fenders and lights. (Hitch must be ordered separately.)

Ball Hitch 2 in (50 mm) #043 864

For use with the 430 trailer.

Lunette Eye 3 in (76 mm) #043 863

For use with the 430 trailer.



4 West Four-Wheel Steerable Off-Road Trailer #042 801

A heavy-duty 2570 lb (1166 kg) capacity trailer designed for use in mines, quarries, and other rough terrain. Has narrow 22 ft (6.7 m) turning radius. Includes 3 in lunette eye, universal hitch and safety chains.

Note: Trailers are shipped unassembled.

See page 4 for specifications on each trailer.

Trailer Specifications (Subject to change without notice.)

Model	Gross Axle Weight Rating	Gross Vehicle Weight Rating	Net Payload	Height of Bed	Road Clearance	Track (Center to center of tires)	Standard Tires (Standard rating or P-size rating)	Dimensions	Net Weight
HWY-224 OFR-224	3500 lb (1588 kg)	2960 lb (1343 kg)	2650 lb (1202 kg)	18-1/2 in (470 mm)	7-1/2 in (191 mm)	52 in (1321 mm)	B78-13C	Length: 122-1/2 in (3112 mm) Width: HWY-61 in (1549 mm)* OFR-58-1/2 in (1486 mm)	355 lb (161 kg)
HWY-430	2200 lb/axle (998 kg/axle)	4280 lb (1941 kg)	3750 lb (1701 kg)	19-1/4 in (489 mm)	8-1/2 in (216 mm)	52 in (1321 mm)	B78-13B	Length: 156-1/2 in (3975 mm) Width: 61 in (1549 mm)*	530 lb (240 kg)
4 West	2000 lb/axle (907 kg/axle)	3000 lb (1361 kg)	2570 lb (1166 kg)	21-1/4 in (540 mm)	8 in (203 mm)	55-1/4 in (1403 mm)	B78-13	Length: 91 in (2311 mm)** Width: 61-1/4 in (1556 mm)	430 lb (1950 kg)

*Width at outside of fenders. **Does not include tongue.

Ordering Information

Equipment and Factory Options	Stock No.	Description	Qty.	Price
Miller Du-Op™	Base Model International Model	#903 696 #903 696-01-1	Dry Battery	
Ether Starting Aid Kit	#041 481			
FA-1D Lockable Flame Arrestor Fuel Cap	#042 726	Field		
Spark Arrestor (Muffler) Kit	#041 928	Field		
Wire Feeders				
Suitcase 8VS Wire Feeder	#194 890	Includes contactor and gas valve. See Lit. Index No. M/6.4		
Suitcase 12VS Wire Feeder	#194 941	Includes contactor and gas valve. See Lit. Index No. M/6.4		
MIG Guns and Consumables		See Lit. Index No. M/10.0 and M/13.4		
Stick Accessories				
Welding Leads	#173 851 #043 952	2/0, 350 A, 100% duty cycle, 50 ft stinger, 50 ft work clamp 2/0, 300 A, 100% duty cycle, 100 ft stinger, 50 ft work clamp		
Remote Controls				
RHC-14	#129 340	Hand control		
Extension Cords	#122 973 #122 974 #122 975	25 ft (7.6 m), 14-pin remote controls 50 ft (15.2 m), 14-pin remote controls 75 ft (22.9 m), 14-pin remote controls		
Trailers and Hitches				
HWY-224 Trailer	#043 805	Trailer with lights, fenders and 2 in ball hitch		
OFR-224 Trailer	#043 802	Trailer with 2 in ball hitch		
Lunette Eye, 2-1/2 in	#043 824	Replaces the 2 in ball hitch on the HWY-224 or OFR-224		
Cable Tree	#043 826	Trailer mounted cable holder for HWY-224, OFR-224 or HWY-430		
HWY-430 Trailer	#043 806	Hitch required		
Ball Hitch, 2 in	#043 864	For HWY-430 only		
Lunette Eye, 3 in	#043 863	For HWY-430 only		
4-West Trailer	#042 801	Four-wheel steerable implement trailer		

Date:

Total Quoted Price:



Distributed by: